

SISTEMA ELEVATÓRIO ETV 460A

Parts included with your Flat Lift

- Lift unit (#1)
- Power supply (#2)
- R.F. Module (#3)
- Rocker switch (#4)
- Remote Control (#5)

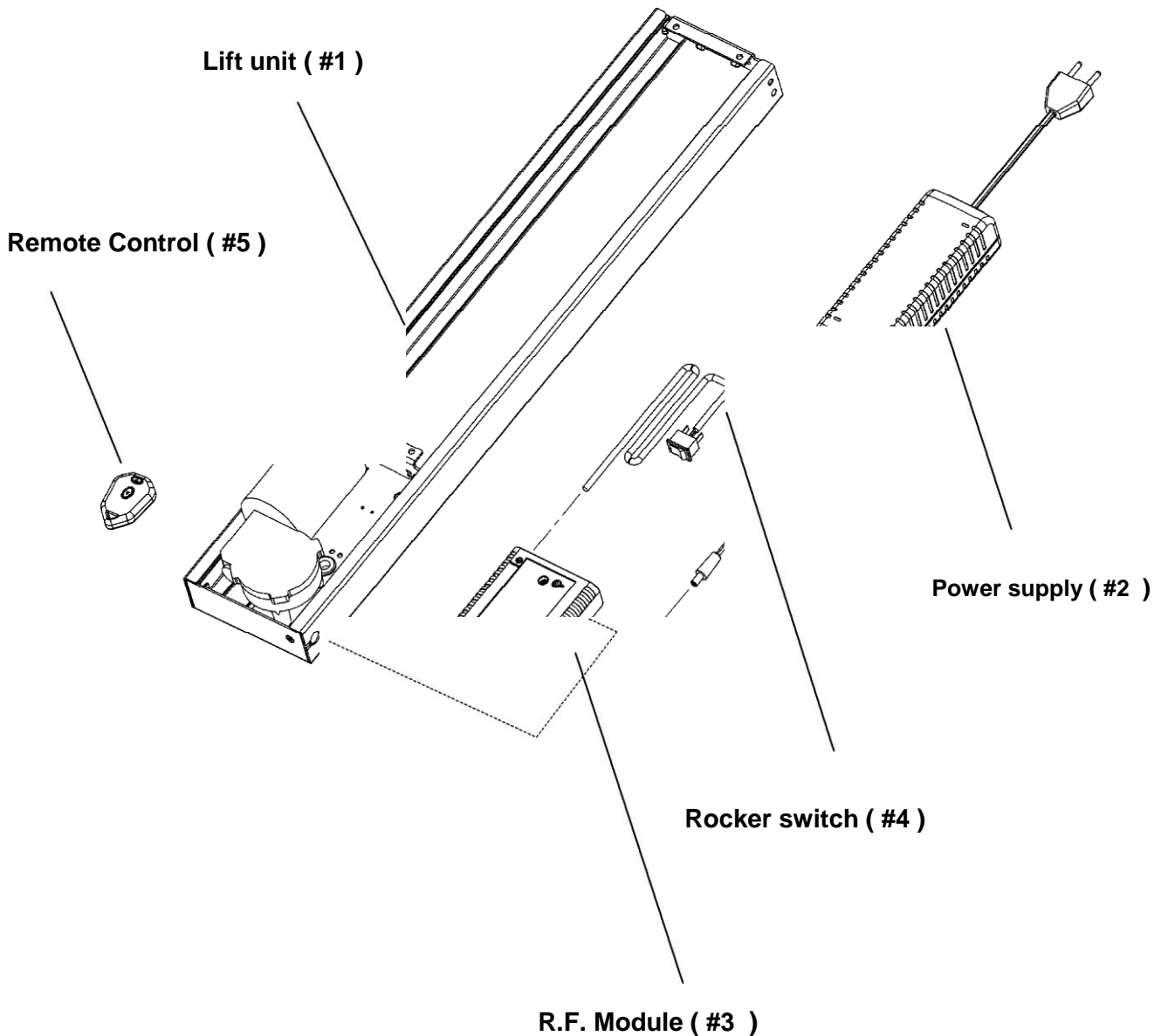

Load: Min. 5 kg / Max. 50 kg

Reverse function setting; Lift configured for standard vertical mounting – see possibilities in Remote system instruction.

SISTEMA ELEVATÓRIO ETV 460A

Important safety Instructions

CAUTION: Before you begin any of the Installation procedures on page 4, read and follow the warnings and safety instructions on this page.

WARNING ! THIS IS NOT A TOY !

**WARNING ! CHILDREN SHOULD NOT OPERATE LIFT OR
REMOTE CONTROL !**

Use the following safety guidelines to help protect your lift from potential damage and to en-sure your own personal safety.

- Read all the installation instructions before testing or installing your lift.
- Read and follow all safety instructions.
- Keep remote control out of reach of children.
- To prevent bodily injury keep hands and clothing away from the lift while the lift is in operation.
- Before installing the lift or working with its connections, unplug the lift from the electrical shock.
- Do not install the lift, power supply or R.F. module in places subject to extreme temperatures for example near a radiator, or heating vent.
- To avoid damaging the power supply, R.F. module and power cord, do not put anything on it or place it where it could become damaged.
- Unplug the lift in the following conditions:
 - When the power cord or plug is damaged or frayed.
 - If liquid has spilled into the lift, power supply or RF module.
 - If the lift, power supply or RF module has been exposed to rain or water.
 - If the lift exhibits a distinct change in performance, indicating a need for servicing.
- MANUFACTURERS who build this Flat Lift into other products or use it with other products, MUST make sure to prevent bodily injury. The MANUFACTURER is responsible to give the end user proper warnings and instructions for use.

SISTEMA ELEVATÓRIO ETV 460A

Main measures

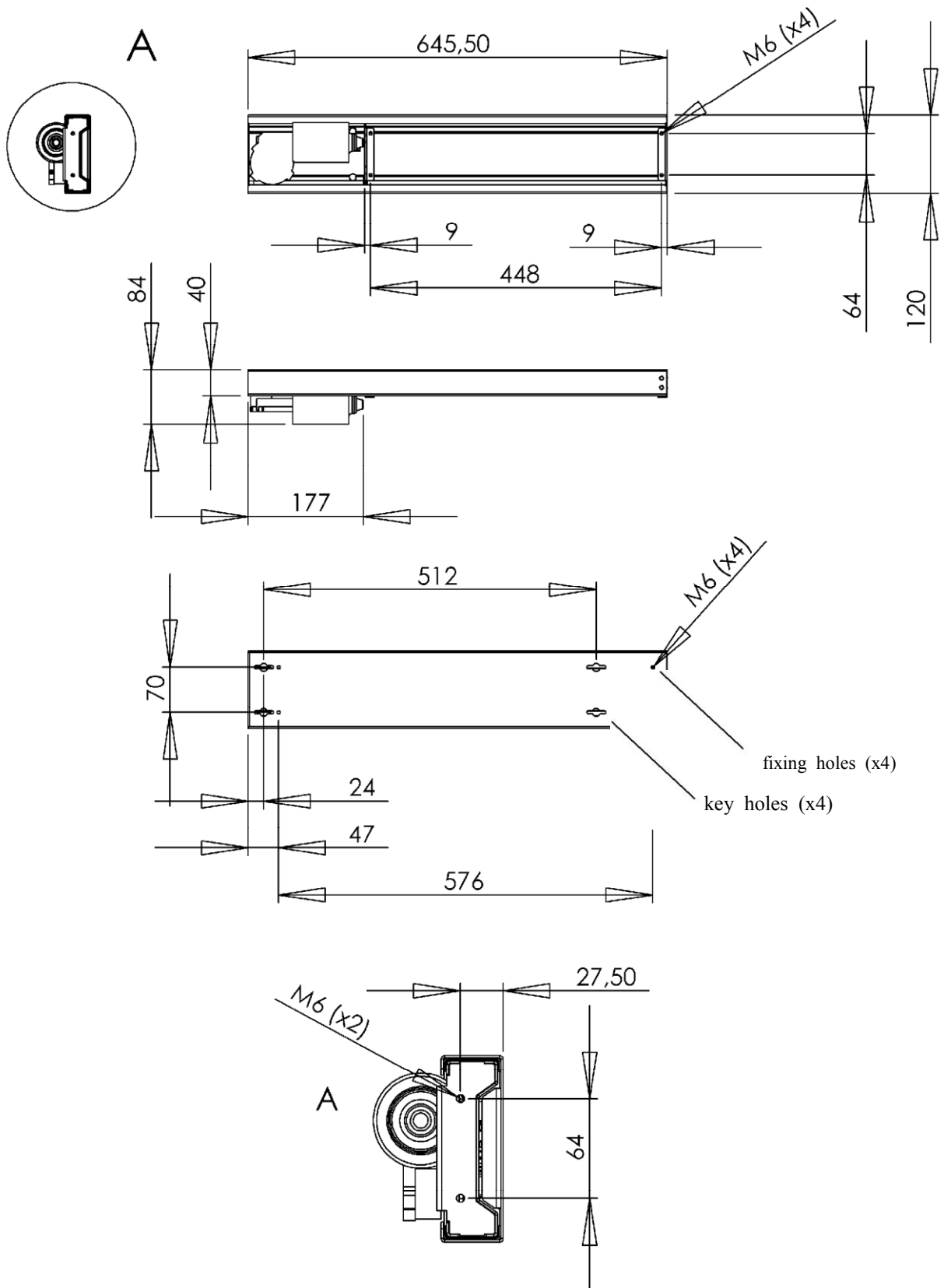

SISTEMA ELEVATÓRIO ETV 460A

Mounting guideline

- 1) Remove all contents from packaging and compare with parts list.
- 2) Place the lift unit (#1) on e.g. the back panel of cabinet in a location that will allow full up and down movement of the lift.
- 3) Fasten the unit securely to the cabinet. Screws must be appropriate for the material being used.
- 4) Connect the plugs from lift unit (#1) and power supply (#2) to R.F. Module (#3). Please also refer to the user instruction packed along with the remote unit.
- 5) Mount rocker switch (#4) on wanted location by cutting a hole and pressing the switch into place. Secure excess wire to keep away from moving parts.
- 6) Plug the power cord into wall outlet and test the lift. If the unit doesn't work, check all connections and retry. If still not working, refer to trouble shooting guide.

User instruction, RF remote system

Installation

- connect the power supply and the motor unit to the remote receiver. 2 different plug sizes make this connection only possible to make in the right way
- after having connected the plugs, the blue light will be lightning
- push the emitter buttons and the motor unit will move up and down
- for stopping the motion one of the buttons need to be pushed

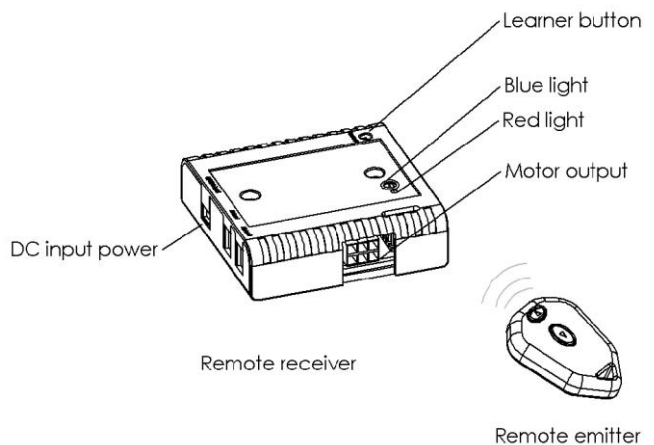

Learning

- if the remote receiver do not respond when pushing the emitter buttons, reset the re-ceiver. After that, code the emitter and receiver together again

Coding

- push the learner button on the receiver for less than 1 sec.
- push one of the emitter buttons
- the red light will start flashing
- push one of the emitter buttons again and the red light will turn off
- the units now are coded together with a unique code

SISTEMA ELEVATÓRIO ETV 460A

Reset

- push and hold down the learner button on the receiver for 10 sec. (will be reset when the red light turns off).

External rocker switch

- the external rocker switch can be connected to the receiver, if a fixed operation unit is required.

Trouble shooting

- check the plug connections
- check whether the blue light is on
- reset the receiver and make a new coding

Setting options for operation of lift

This remote system has 4 'jumpers' inside the remote receiver box, these can be lifted and positioned 'Left' or 'Right' depending of how the functionality of the lift should be.

Jumper A – Power safety cut off time Default 'Left' = 60 seconds. If moved to right position then the lift will power off automatically after the motor has run for 20 seconds.

Jumper B – Remote emitter function Default 'Right' = the buttons on the emitter only need to be pushed once for activation. If moved to the left position then the emitter button will need to be held down during the operation of the lift, ie..for use where a higher level of safety may be required.

Jumper C – Auto-reverse time (type A lifts only)

Default 'Right' = a reverse period of 1 second. If moved to the left position, the reverse time is reduced to 0.6 of a second.

Jumper D – Using the lift upside down (type A lifts only)

Default 'Right' = normal operation in an upright position ie.. to raise a TV up and down from a floor standing cabinet. If moved to the left position the reverse function will work with the lift mounted up-side down ie.. to lower down and up a TV from the bottom of a wall mounted. If no reverse function is required then remove the jumper.

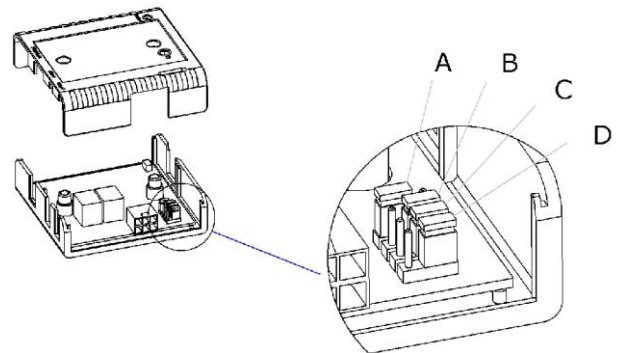

SISTEMA ELEVATÓRIO ETV 460A

Change of battery in emitter (type 27A/12V)

- remove lid on back side
- lift up battery
- place new battery

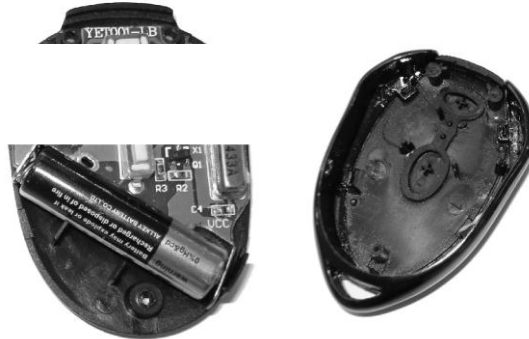

FCC Statement

This device complies with Part 15 of the FCC rules. Operation is subject to the following two conditions; 1) This device may not cause any harmful interference and 2) This device must accept any interference received, including interference that may cause undesired operation.

Declaration of conformity

We hereby declare, under our sole responsibility that the following products:

- Sistema elevatório product type ETV 460 A

which are covered by this statement, are in conformity with the following standards and other normative documents::

- Counsel Directive 89/336/EØF with later changes
- Counsel Directive 73/23/EØF with later changes

